

Liquid Collector Ejector Type **HEP500-04**

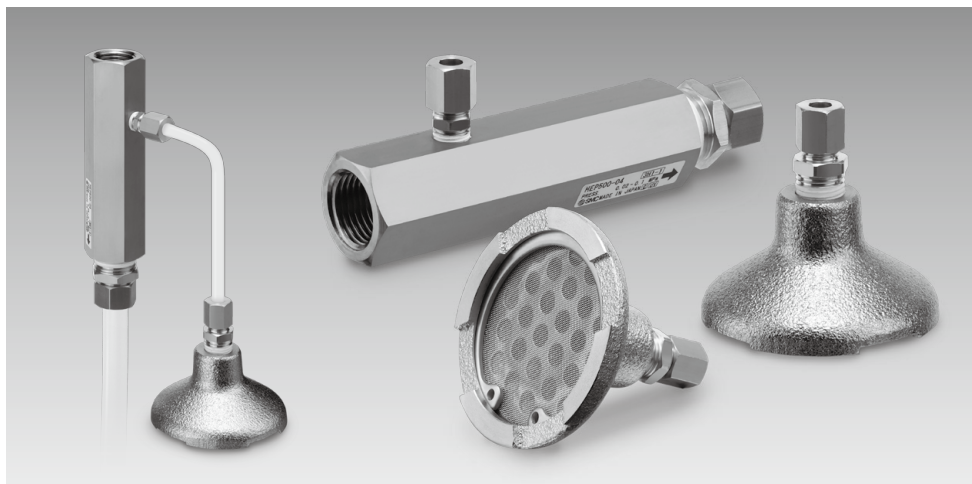

AL800
AL900
ALF
ALT
ALD
ALB
LMU
ALIP
AEP
HEP

Resource Saving/Labor Saving — Collects and reuses leaked fluids such as valuable cutting oil and grinding oil

Collects leaked fluids such as valuable cutting oil and grinding oil.

This equipment collects cutting oil and grinding oil that sticks to and leaks from pumps or processed materials, shavings, etc.

No need for workers to carry out tasks such as collecting fluid.

Freedom from the troublesome task of collecting leaked fluid.

Compact – easy mounting and operation

This equipment is compact, uses minimal space, and not only are mounting and operation simple, but also maintenance is not needed.

Can be driven by an already-installed pump

Already-installed pumps can power these collectors. There is no need to provide a fresh source of energy.

Specifications

Model		HEP500-04	
Fluid		Water-soluble	Non-water soluble
Collected fluid		Cutting oil/Grinding oil	Cutting oil/Grinding oil
Operating fluid pressure range		0.02 to 0.1 MPa	
Collected flow rate L/min		0.8 to 2.7	0.01 to 1
Port size*	Liquid collector	IN	Rc1/2
	OUT	Nylon tube $\phi 12/\phi 9$	
	Leaked fluid suction inlet	With fitting (H06-01S)	
Strainer		With fitting (H06-02S)	
Strainer filtration		60 mesh gauze	
Material	Liquid collector body	Brass, Electroless nickel plated	
	Strainer body	Cast iron, Electroless nickel plated	
Weight	Liquid collector	500 gf	
	Strainer	200 gf	

* This product includes a strainer supplied with the liquid collector.

* Prepare nylon tube T0645 separately to connect the liquid collector with the strainer before use.

Application Example

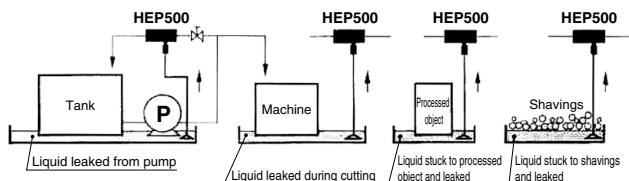

HEP500-04

Flow Rate Characteristics

Diluted water-soluble cutting oil

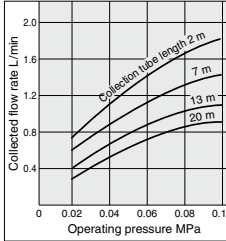

Non-water soluble cutting oil: Dynamic viscosity 20cSt

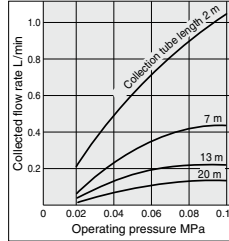

Non-water soluble cutting oil: Dynamic viscosity 50cSt

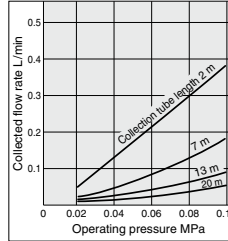

Operating pressure and operating flow rate

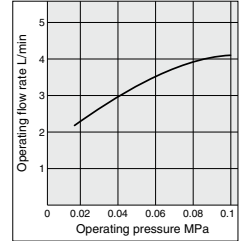

Conditions: 1. Lifting range 1 m. 2. Collection tube (T0645) length

Working Principle

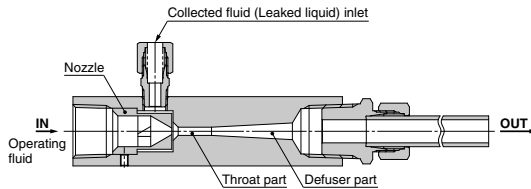

When the operating fluid is flown from the IN side (nozzle, throat part, diffuser part) at a certain flow rate or more, the negative pressure is generated in the throat part. This negative pressure is used to suck up the leaked liquid and discharge it together with the operating fluid toward the OUT side to return it to the tank.

Piping

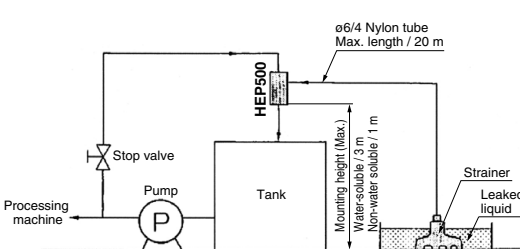

Dimensions

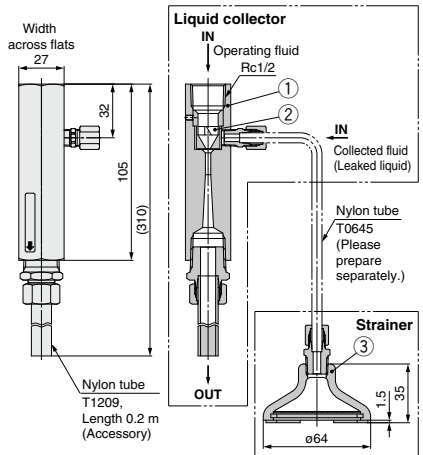

Main Parts

No.	Description	Material	Note
1	Body	Brass	Electroless nickel plated

Parts List

No.	Description	Material	Part no.
2	Nozzle assembly	Brass	P257021
3	Strainer body assembly	—	P257014A

Piping Precautions

- Branch the piping that supplies cutting oil or grinding oil to the processing machinery, mount a stop valve, and connect the piping to the IN side of the body. Adjust the operating pressure of the liquid collector using the stop valve.
- Mount the discharge port facing in a vertical or horizontal direction.
- When mounting the liquid collector, the mounting height is 3 m for water-soluble liquids and 1 m for non-water soluble liquids. However, the collector's performance will decline if it is mounted in a high place, so mount the collector in as low a place as possible.
- Use a nylon tube to connect the liquid collector with the strainer. The size should be $\phi 6$ or $\phi 4.5$ and length should be a maximum of 20 m, but the collector's performance will decline as the tube gets longer, so be sure to use as short a connecting tube as possible.
- Be sure to connect the nylon tube (T1209) supplied with the product to the OUT side of the liquid collector. If a tube other than the nylon tube supplied with the product is used, this may cause the capability of the liquid collector to lower. Additionally, do not put the tube end in the liquid. This may cause the back pressure to be applied, resulting in poor performance.

Handling Precautions

- The drive pressure, fluid, fluid viscosity, collection tube length, and/or pump head may affect the collected flow rate, and the liquid may not be collected or backflow to the strainer side depending on the conditions. So, use the liquid collector after checking it under operating conditions while referring to its flow rate characteristics.
- During collection of leaked liquid, if there is a decline in performance, or a total failure to collect liquid occurs, check for the following potential sources of trouble.
 - When the nozzle is clogged: If the nozzle is clogged, loosen the set screw (M3 x 0.5 hexagon socket head screw), remove the nozzle from the body and clean it.
 - When the strainer gauze is clogged: After removing the C-type snap ring (nominal size 52), remove the gauze and clean it.
- Liquids cannot be collected by the air.