

# Large Size 3 Port Solenoid Valve

## VP3145/3165/3185 Series

### Rubber Seal



[Option]

Note) CE/UKCA-compliant: D/DL/DS/DZ only (Electrical entry)

### Large flow capacity, small exhaust resistance

(Refer to "Flow Rate Characteristic" table.)

### Easy conversion to N.C. or N.O.

Function plate makes it possible to use as a N.C. or N.O. valve with the port unchanged.

### Possible to use in vacuum or under low pressures

Vacuum: Up to 101.2 kPa  
Low pressure: 0 to 0.2 MPa

### Free mounting orientation

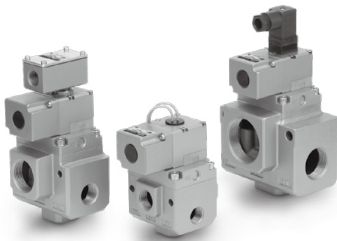

#### Symbol

Internal pilot  
<Standard>

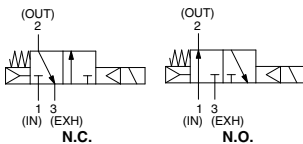

External pilot

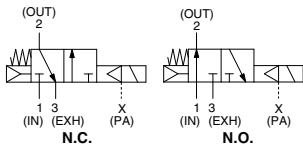

Note) N.O. valve operates properly only when appropriate pressure is applied to the pilot.



**Made to Order**

(Refer to pages 1313 to 1315 for details.)

### How to Order

VP3 1 4 5 [ ] - 04 1 G A [ ] - [ ] - [ ]

VP series 3 port solenoid valve

Number of solenoids

1	Single
---	--------

Body size

4	1/2
6	1
8	1 1/2

Body type

5	Body ported
---	-------------

Valve option

Nil	For general
V	For vacuum/low pressure

Port size (IN, OUT port)

Symbol	Port size R <sub>c</sub> (Nominal size)	VP3145	VP3165	VP3185
03	3/8 (10A)	●		
04	1/2 (15A)	●		
06	3/4 (20A)	●	●	
10	1 (25A)		●	
12	1 1/4 (32A)		●	●
14	1 1/2 (40A)			●
20	2 (50A)			●

Coil rated voltage

1	100 VAC, 50/60 Hz
2	200 VAC, 50/60 Hz
3*	110 VAC, 50/60 Hz
4*	220 VAC, 50/60 Hz
5	24 VDC
6*	12 VDC
7*	240 VAC, 50/60 Hz

\* Semi-standard

For other rated voltages, please consult with SMC.

CE/UKCA-compliant

NH	—
Q	CE/UKCA-compliant (Note)

Note) Electrical entry: D/DL/DS/DZ only

Thread type

NH	Rc
F	G
N	NPT
T	NPTF

Pilot option

Nil	Standard (Internal pilot)
1	External pilot

Type of actuation

A	N.C. (Normally closed)
B	N.O. (Normally open)

Electrical entry

		CE/UKCA-compliant
G	Grommet	—
T	Conduit terminal	—
D	DIN terminal	●
TL*	Conduit terminal with indicator light	—
TS*	Conduit terminal with surge voltage suppressor	—
TZ*	Conduit terminal with light/surge voltage suppressor	—
DL*	DIN terminal with indicator light	●
DS*	DIN terminal with surge voltage suppressor	●
DZ*	DIN terminal with light/surge voltage suppressor	●

\* Semi-standard

SYJ

VQZ

VP

VG

VP3

### How to Order Pilot Valve Assembly

VT3113 - 00 1 G - [ ]

Electrical entry

		CE/UKCA-compliant
G	Grommet	—
T	Conduit terminal	—
D	DIN terminal	●
TL*	Conduit terminal with indicator light	—
TS*	Conduit terminal with surge voltage suppressor	—
TZ*	Conduit terminal with light/surge voltage suppressor	—
DL*	DIN terminal with indicator light	●
DS*	DIN terminal with surge voltage suppressor	●
DZ*	DIN terminal with light/surge voltage suppressor	●

CE/UKCA-compliant

NH	—
Q	CE/UKCA-compliant (Note)

Note) Electrical entry: D/DL/DS/DZ only

Coil rated voltage

1	100 VAC, 50/60 Hz
2	200 VAC, 50/60 Hz
3*	110 VAC, 50/60 Hz
4*	220 VAC, 50/60 Hz
5	24 VDC
6*	12 VDC
7*	240 VAC, 50/60 Hz

\* Semi-standard

For other rated voltages, please consult with SMC.

\* Semi-standard

Note) The pilot valve assembly shown above includes the function plate and gasket.



# VP3145/3165/3185 Series

## External Pilot

Use external pilot model in the following cases.

- Vacuum or low pressure (0.2 MPa or less): Vacuum/Low pressure type
- Using the valve with supply port external throttle: General type
- Air pressure of supply port is slow: General type
- Resistance in outlet side is small in case of air blowing or filling an air tank: General type

Note 1) Keep external pilot pressure within the pressure range below.

Note 2) Conversion of internal pilot and external pilot can not be done.

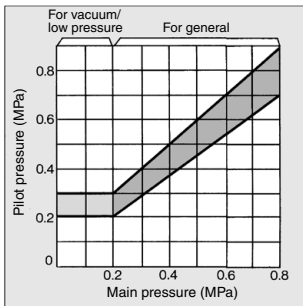

## Specifications

<b>Fluid</b>		Air							
<b>Type of actuation</b>		N.C. or N.O. (Convertible)							
<b>Pilot type</b>		Internal pilot			External pilot				
		For general		For vacuum/low pressure	For general	For general			
<b>Operating pressure range (MPa)</b>	<b>Main pressure</b>	0.2 to 0.8		-101.2 kPa to 0.2		0.2 to 0.8			
	<b>Pilot pressure</b>			0.2 to 0.3		Refer to the graph left.			
<b>Ambient and fluid temperature (°C)</b>		0 (No freezing) to 60							
<b>Response time (ms) <sup>(1)</sup> (at the pressure of 0.5 MPa)</b>		ON	AC	30 or less		OFF	AC	30 or less	
<b>Max. operating frequency (Hz)</b>			DC	40 or less		DC	30 or less		
<b>Lubrication <sup>(2)</sup></b>		Required (Equivalent to turbine oil Class1 ISO VG32)							
<b>Manual override</b>		Yes (Non-locking)							
<b>Mounting orientation</b>		Unrestricted							
<b>Impact/vibration resistance (m/s<sup>2</sup>) <sup>(3)</sup></b>		150/50							

Note 1) Based on dynamic performance test. JIS B 8419: 2010. (Coil temperature: 20°C, at rated voltage, without surge voltage suppressor)

Note 2) This solenoid valve requires lubrication. Use turbine oil Class 1 (ISO VG32).

Note 3) Impact resistance: No malfunction occurred when it is tested with a drop tester in the axial direction and at the right angles to the main valve and armature in both energized and de-energized states every once for each condition. (Values at the initial period)

Vibration resistance: No malfunction occurred in a one-sweep test between 45 and 1000 Hz. Test was performed at both energized and de-energized states in the axial direction and at the right angles to the main valve and armature. (Values at the initial period)

## Solenoid Specifications

<b>Electrical entry</b>	<b>Standard</b>	Grommet (G), Conduit terminal (T) DIN terminal (D)
	<b>Option</b>	Conduit terminal with indicator light (TL), Conduit terminal with surge voltage suppressor (TS), Conduit terminal with light/surge voltage suppressor (TZ), DIN terminal with indicator light (DL), DIN terminal with surge voltage suppressor (DS), DIN terminal with light/surge voltage suppressor (DZ)
<b>Coil rated voltage (V)</b>	AC (50/60 Hz) DC	100, 200, 110 *, 220 *, 240 * 12 *, 24
<b>Allowable voltage fluctuation</b>		-15 to +10% of rated voltage
<b>Apparent power <sup>Note)</sup></b>	AC	Inrush 73 VA (50 Hz), 58 VA (60 Hz)
	DC	Holding 28 VA (50 Hz), 17 VA (60 Hz)
<b>Power consumption <sup>Note)</sup></b>		12 W

\* Semi-standard

Note) At rated voltage

## Flow Rate Characteristics/Weight

Valve model	Port size		Flow rate characteristics						Weight * (kg)
			1 → 2 (IN → OUT)			2 → 3 (OUT → EXH)			
	1 (IN), 2 (OUT)	3 (EXH)	C [dm <sup>3</sup> /(s·bar)]	b	Cv	C [dm <sup>3</sup> /(s·bar)]	b	Cv	Grommet
VP3145	3/8	3/4	19	0.43	5.5	18	0.47	5.4	1.5
	1/2		23	0.32	6.2	21	0.39	5.8	
	3/4		28	0.36	7.6	26	0.35	7.0	

Valve model	Port size		Effective area (mm <sup>2</sup> )		Weight * (kg)
			1 → 2 (IN → OUT)	2 → 3 (OUT → EXH)	
VP3165	1 (IN), 2 (OUT)	3 (EXH)	230	280	2.0
	3/4		280	310	
	1		310	330	
	1 1/4		570	650	
VP3185	1 1/2	2	650	670	2.8
	2		650	670	
	2		650	670	

\* For grommet  
Conduit terminal... +0.2 kg

## Construction/Internal Pilot

As in the figure below, this pilot-operated solenoid valve consists of a compact 3 port solenoid valve as the pilot valve and a large 3 port valve as the main valve.

The pilot valve controls opening and closing the main valve. N.C. or N.O. function conversion can be done by switching the pilot passage.

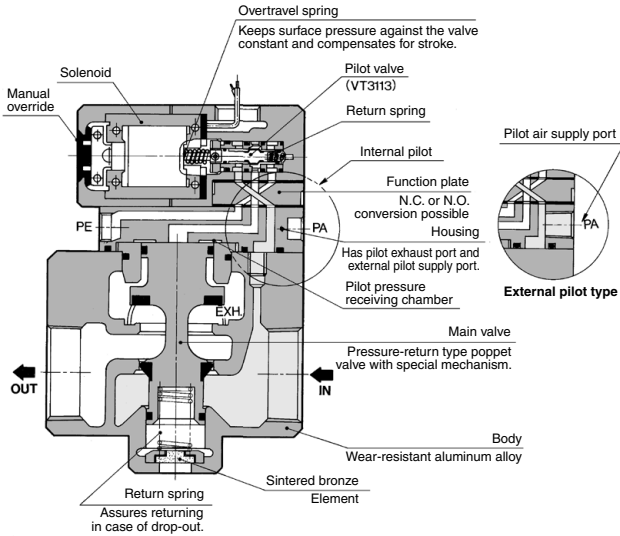

Note) Pilot valve and body are shown in a different direction from the actual product in order to show the construction and air passage.

### Piping (Vacuum Use)

1. Piping in general:

- EXH port = Vacuum pump/ Blower } (Suction side)
- OUT port = Tank/ Vacuum pad } (Load side)
- IN port = Plug (2 port valve)  
Air releasing  
Air pressure-in

2. Following the above piping, vacuum passage is switched between OUT and EXH, therefore, N.C./N.O. indication on the function plate and switching of the vacuum passage are reversed; N.C. (Normally closed) in vacuum passage are reversed:

"N.C." indicated on the plate  
→ N.O. in vacuum passage  
(Normally open)

"N.O." indicated on the plate  
→ N.C. in vacuum passage  
(Normally closed)

### N.C./N.O. Conversion

To convert valve operation from N.C. to N.O. or N.O. to N.C., remove the pilot valve, move the function plate along the gasket, both top and bottom until the mark ▶ meets N.C. (N.O.)

Please note however, that the N.O. valve functions properly only when the appropriate pressure is applied to the valve.

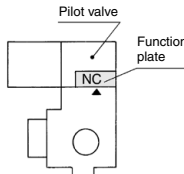

SYJ

VQZ

VP

VG

VP3

# VP3145 Series

## Dimensions: VP3145

Grommet: VP3145□-□□G<sub>B</sub><sup>A</sup>□

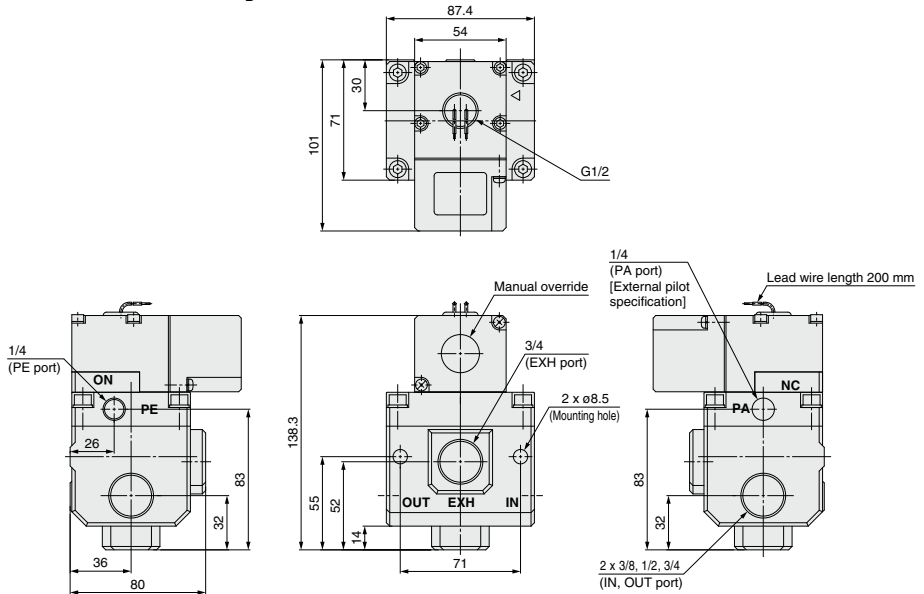

Note) External pilot port (PA port) 1/4 is processed for threads in external pilot model only.

Conduit terminal: VP3145□-□□T<sub>B</sub><sup>A</sup>□

DIN terminal: VP3145□-□□D<sub>B</sub><sup>A</sup>□

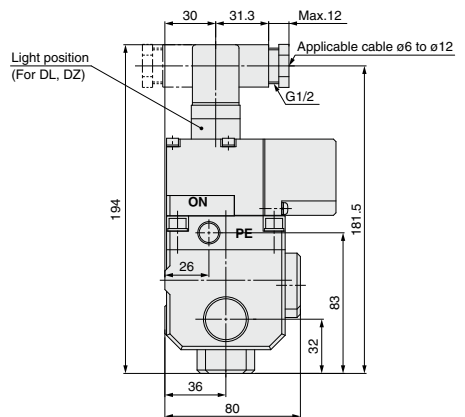
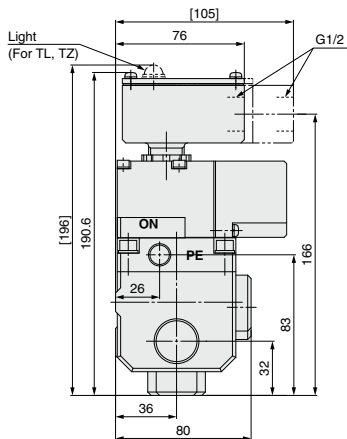

[ ]: With indicator light (TL, TZ)

## Dimensions: VP3165

Grommet: VP3165□-□□G<sub>B</sub><sup>A</sup>□

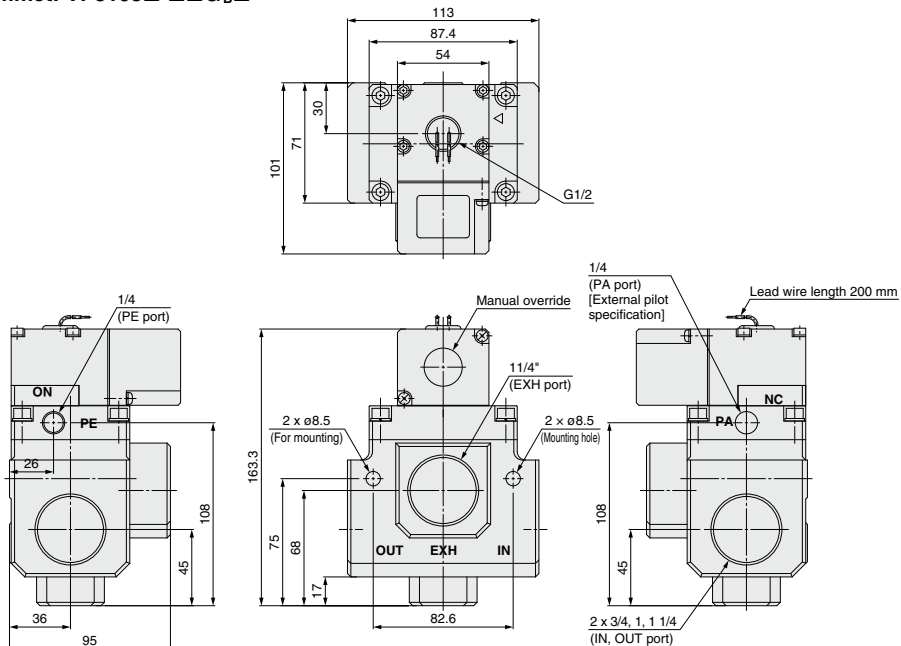

Note) External pilot port (PA port) 1/4 is processed for threads in external pilot model only.

Conduit terminal: VP3165□-□□T□<sub>B</sub><sup>A</sup>□

DIN terminal: VP3165□-□□D□<sub>B</sub><sup>A</sup>□

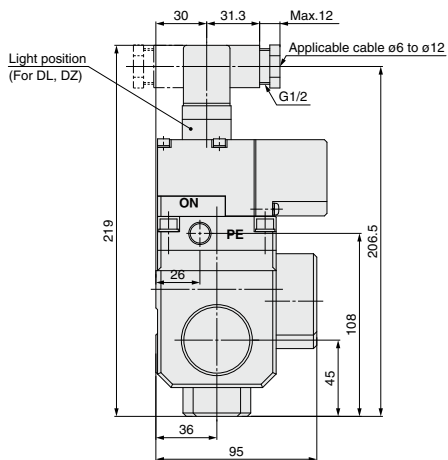
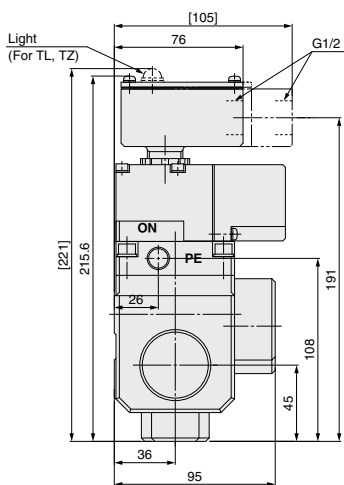

[ ]: With indicator light (TL, TZ)

# VP3185 Series

## Dimensions: VP3185

Grommet: VP3185□-□□G<sub>B</sub>□

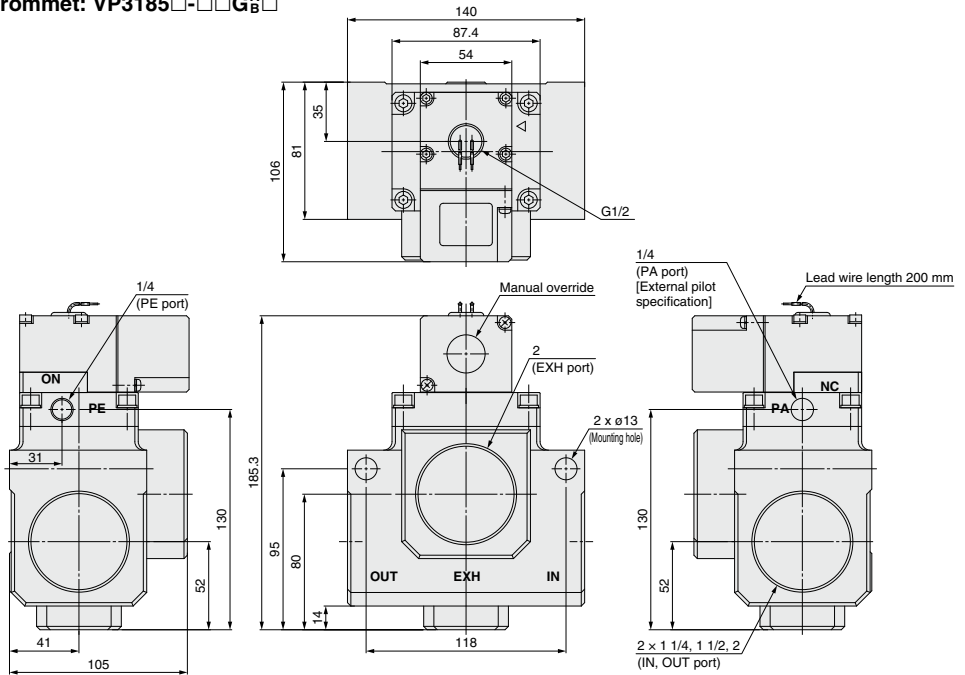

Note) External pilot port (PA port) 1/4 is processed for threads in external pilot model only.

Conduit terminal: VP3185□-□□T<sub>B</sub>□

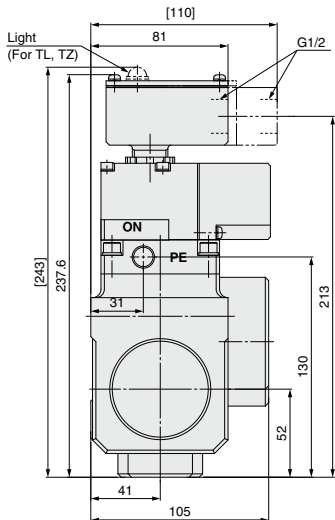

DIN terminal: VP3185□-□□D<sub>B</sub>□

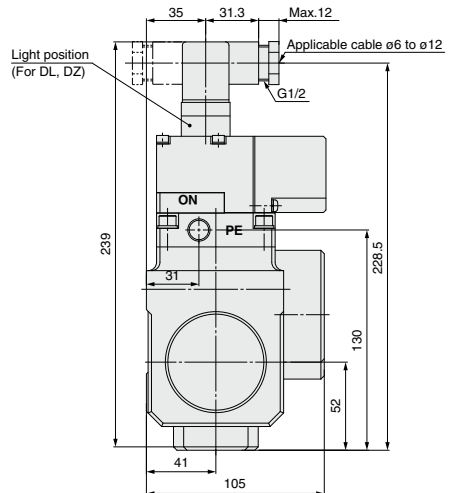

[ ]: With indicator light (TL, TZ)

# VP3145/3165/3185 Series

## Made to Order



Please contact SMC for detailed dimensions, specifications and lead times.

Symbol

### 1 Main Value Double Acting Type

-X80, -X81

VP31 4 5-06 1 D Z A 1-N-X81

**Body size**

4	1/2
6	1
8	1 1/2

**Port size (IN, OUT port)**

Symbol	Port size	VP3145	VP3165	VP3185
03	3/8	●		
04	1/2	●		
06	3/4		●	
10	1		●	
12	1 1/4		●	●
14	1 1/2		●	●
20	2		●	●

**Thread type**

NII	Rc
F	G
N	NPT
T	NPTF

**Type of actuation**

X80	Double solenoid
X81	Single solenoid

**External pilot**

**Passage, Type of actuation**

A	N.C.
B	N.O.

\* In the case of -X80, only N.C. is available.

**Rated voltage**

1	100 VAC (50/60 Hz)
2	200 VAC (50/60 Hz)
3	110 VAC (50/60 Hz)
4	220 VAC (50/60 Hz)
5	24 VDC
6	12 VDC
7	240 VAC (50/60 Hz)

**Electrical entry**

Symbol	Description	CE/UKCA-compliant	
		DC	AC
G	Grommet (300 mm)	●	●
H	Grommet (600 mm)	●	●
T	Conduit terminal	●	●
D	DIN terminal	●	●
DO	terminal	●	●
L	L plug connector	●	●
LN	With lead wire	●	●
LO	Without lead wire	●	●
M	M plug connector	●	●
MN	With lead wire	●	●
MO	Without lead wire	●	●

**Light/Surge voltage suppressor**

Symbol	Description	DC	AC
		●	●
NII	Without light/surge voltage suppressor	●	● (Note 1)
U	With light/surge voltage suppressor	●	—
Z	With light/surge voltage suppressor	—	●

Note 1) AC type has a surge voltage suppressor, since a rectifier is built into the product.

\* In the DIN terminal type, since a light is installed in the connector, DOU and DOZ are not available.

### How to Order Pilot Valve Assembly

VF3 1 40 K-1 D Z 1

**Type of actuation**

1	Single (X81)
2	Double (X80)

**Pressure specification**

**K** High pressure type

Note) High pressure type should be selected for this product.

**Rated voltage**

1	100 VAC (50/60 Hz)
2	200 VAC (50/60 Hz)
3	110 VAC (50/60 Hz)
4	220 VAC (50/60 Hz)
5	24 VDC
6	12 VDC
7	240 VAC (50/60 Hz)

**Light/Surge voltage suppressor**

Symbol	Description	DC	AC
		●	●
NII	Without light/surge voltage suppressor	●	● (Note 1)
U	With light/surge voltage suppressor	●	—
Z	With light/surge voltage suppressor	—	●

Note 1) AC type has a surge voltage suppressor, since a rectifier is built into the product.

\* In the DIN terminal type, since a light is installed in the connector, DOU and DOZ are not available.

CE/UKCA-compliant	Electrical entry				
	Grommet	L plug connector	M plug connector	DIN terminal	Conduit terminal
DC	●	●	●	●	●
AC	—	—	—	●	●

SYJ

VQZ

VP

VG

VP3

# VP3145/3165/3185 Series

Symbol  
-X80

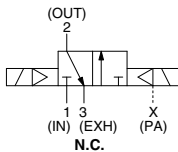

-X81

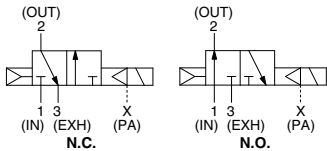

## Specifications

<b>Valve configuration</b>	External pilot 3 port solenoid valve
<b>Type of actuation</b>	Double solenoid (-X80), Single solenoid (-X81)
<b>Fluid</b>	Air
<b>Operating pressure range</b>	-101.2 kPa to 0.8 MPa
<b>Pilot pressure</b>	85 to 115% of main pressure, Min. 0.2 MPa
<b>Ambient and fluid temperature</b>	0 to 50°C (No freezing)
<b>Lubrication</b> <sup>Note 1)</sup>	Required (Equivalent to turbine oil Class 1 ISO VG32)
<b>Mounting orientation</b>	Unrestricted
<b>Impact/Vibration resistance</b> <sup>Note 2)</sup>	150/50 m/s <sup>2</sup>

Note 1) This solenoid valve requires lubrication. Use turbine oil Class 1 (ISO VG32).

Note 2) Impact resistance: No malfunction occurred when it is tested with a drop tester in the axial direction and at the right angles to the main valve and armature in both energized and de-energized states every once for each condition. (Values at the initial period)

Vibration resistance: No malfunction occurred in a one-sweep test between 45 and 1000 Hz. Test was performed at both energized and de-energized states in the axial direction and at the right angles to the main valve and armature. (Values at the initial period)

## Solenoid Specifications

<b>Electrical entry</b>	Grommet, Conduit terminal, DIN terminal L plug connector, M plug connector	
<b>Coil rated voltage (V)</b>	AC (50/60 Hz)	100, 200, 110, 220, 240
	DC	24, 12
<b>Allowable voltage fluctuation</b>	±10% of rated voltage	
<b>Apparent power (VA)</b> <sup>Note)</sup>	AC*	1.55 (With indicator light: 1.65) DIN/Conduit terminal with indicator light: 1.7
	DC	1.5
<b>Power consumption (W)</b> <sup>Note)</sup>	Without indicator light	1.5
	With indicator light	1.55, DIN/Conduit terminal with indicator light: 1.75

\* A Rectifying circuit is used in the AC type.

Note) At rated voltage

## ⚠ Caution

Piping and other usage are the same as standard products.

## Dimensions

VP3145-□□DZA1-X81

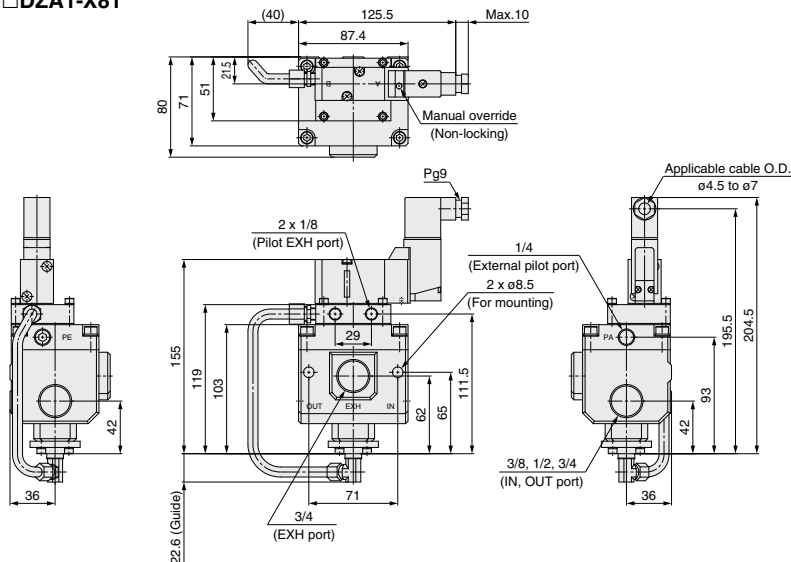

- In the case of B spec. of -X81 (N.O. spec.), VF3140K solenoid has to be positioned at left, when looking at the EXH port in the front face.
- In the case of -X80, VF3240K-□□□1 (Pilot valve) will be mounted.



# Large Size 3 Port Solenoid Valve *VP3145/3165/3185 Series*

## Dimensions

### VP3165-□□DZA1-X81

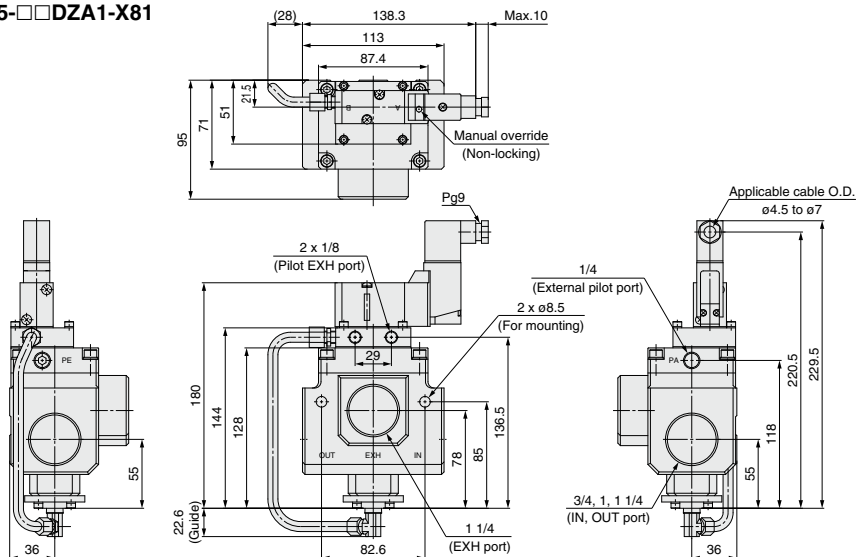

- In the case of B spec. of -X81 (N.O. spec.), VF3140K solenoid has to be positioned at left, when looking at the EXH port in the front face.
- In the case of -X80, VF3240K-□□□1 (Pilot valve) will be mounted.

### VP3185-□□DZA1-X81

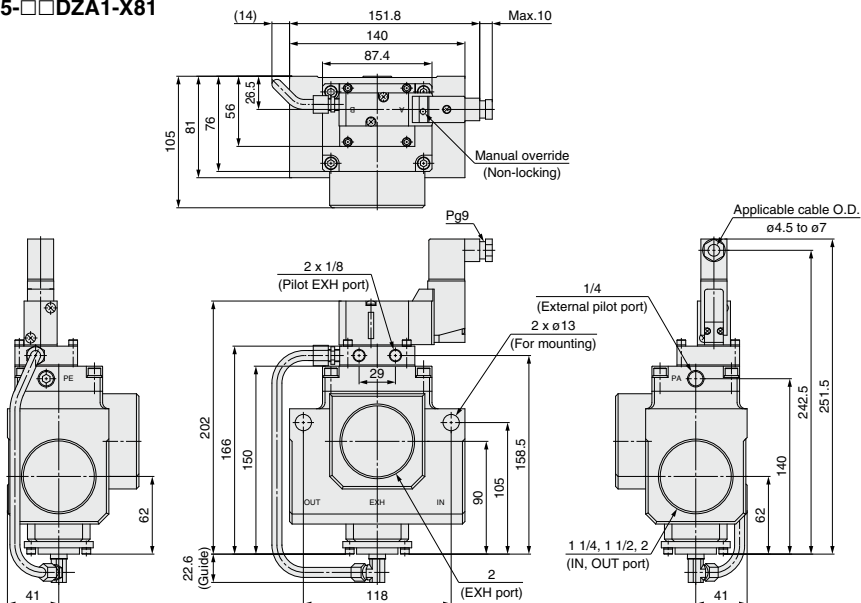

- In the case of B spec. of -X81 (N.O. spec.), VF3140K solenoid has to be positioned at left, when looking at the EXH port in the front face.
- In the case of -X80, VF3240K-□□□1 (Pilot valve) will be mounted.

SYJ
VQZ
VP
VG
VP3



# VP3145/3165/3185 Series Specific Product Precautions

Be sure to read this before handling the products.

Refer to back page 50 for Safety Instructions and pages 3 to 9 for 3/4/5 Port Solenoid Valve Precautions.

## ⚠ Caution

### Piping

If supply port air pressure drops to less than 0.2 MPa, the valve may malfunction. In such a case, use external pilot type. (When throttling IN port, or operating with OUT port open to the atmosphere or in a similar operation.)

### Pressure balance among each port

This solenoid valve is pressure-unbalanced type. Operate it within this pressure range:  $IN \geq OUT \geq EXH$ . If not operated in the range, the valve will malfunction.

### Use as 2 port valve

1. Plug EXH port in case of pressure-in and plug IN port in case of vacuum use.
2. This valve has slight air leakage and can not be used for such purposes as holding air pressure (including vacuum) in the pressure container.

### Supply air

Install an air filter and a lubricator on the upstream side.

### Lubrication

This solenoid valve requires lubrication. Use turbine oil Class 1 (ISO VG32).

### Environment

If using the valve in a dusty environment, install a silencer at EXH port and PE port to prevent dust from entering.

### N.C./N.O. conversion

When converting from N.C. to N.O. and vice versa, note that the equipment to be connected will act reversely.

### How to Calculate the Flow Rate

For obtaining the flow rate, refer to front matter.

## Light/Surge Voltage Suppressor

	Grommet (G)	Conduit terminal (T)	DIN terminal (D)	
With indicator light (L)	None		48 VDC or less 	100 VAC or more 
Surge voltage suppressor (S)				
With light/surge voltage suppressor (Z)	None		48 VDC or less 	100 VAC or more 

\*Items that are marked "With indicator light," "With surge voltage suppressors," and "With light/surge voltage suppressor" are all non-polar types.

## How to Use DIN Terminal

### 1. Disassembly

- 1) After loosening the screw ①, then if the housing ④ is pulled in the direction of the screw ①, the connector will be removed from the body of equipment (solenoid, etc.).
- 2) Pull out the screw ①, then remove the gasket ②.
- 3) On the bottom part of the terminal block ③, there's a cut-off part (indication of an arrow) ③a. If a small flat head screwdriver is inserted between the opening in the bottom, terminal block ③ will be removed from the housing ④. (Refer to graph at right.)
- 4) Remove the cable gland ⑤ and plain washer ⑥ and rubber seal ⑦.

### 2. Wiring

- 1) Pass the cable ⑧ through the cable gland ⑤, washer ⑥, rubber seal ⑦, in this order and then insert them into the housing ④.
- 2) Dimensions of the cable ⑧ are as shown in the right figure. Skin the cable and crimp the crimped terminal ⑨ to the edges.
- 3) Remove the screw ③f from the bracket ③e. (Loosen in the case of Y-shape type terminal.) As shown in the right figure, mount a crimped terminal ⑨, and then again tighten the screw ③f.

Note) Tighten within the tightening torque of 0.5 N·m  $\pm$ 15%.

Note: a) It is possible to wire even in the state of bare wire. In that case, loosen the screw ③f and place a lead wire into the bracket ③e, and then tighten it once again.

b) The maximum size for the round terminal ⑨ is 1.25 mm $\phi$ —3.5 and for the Y terminal is 1.25 mm $\phi$ —4.

c) Cable ⑧ outside diameter:  $\phi 6$  to  $\phi 12$  mm

Note) For the one with outside diameter ranged between  $\phi 9$  to  $\phi 12$  remove the inside parts of the rubber seal ⑦ before using.

### 3. Assembly

- 1) Terminal block ③ connected with housing ④ should be reinstated. (Push it down until you hear the click sound.)
- 2) Putting rubber seal ⑦, plain washer ⑥, in this order into the cable introducing slit on the housing ④, then further tighten the cable gland ⑤ securely.
- 3) By inserting gasket ② between the bottom part of the terminal block ③ and a plug on an equipment, screw in ① on top of the housing ④ and tighten it. Note) Tighten within the tightening torque of 0.5 N·m  $\pm$ 20%.

### Changing the entry direction

The cable entry direction of a connector can be changed as desired (4 directions at 90° intervals), depending on the combination of a housing ④ and a terminal block ③.

### Exploded view

