

Pulse Blow Valve

The peak pressure of repeatedly colliding air permits efficient blowing.

■ Air consumption: Reduced by 50% or more

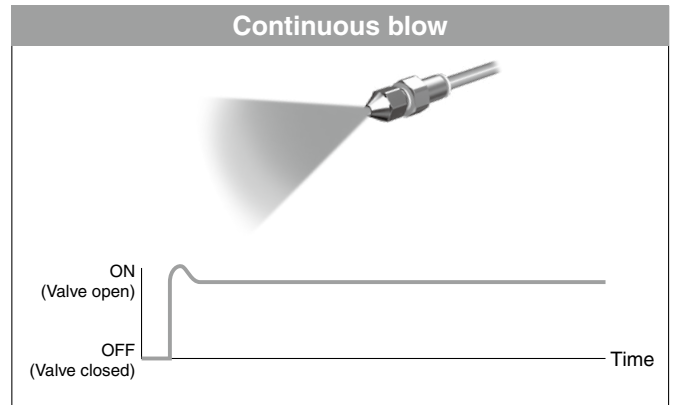
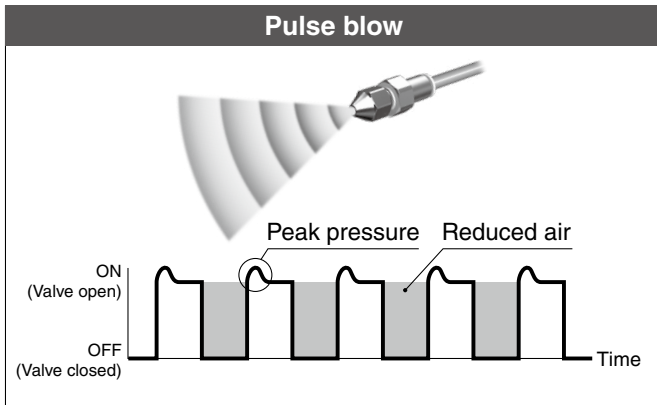

■ Control for pulse generation is not required.

Pulse blow can be used by simply supplying air.

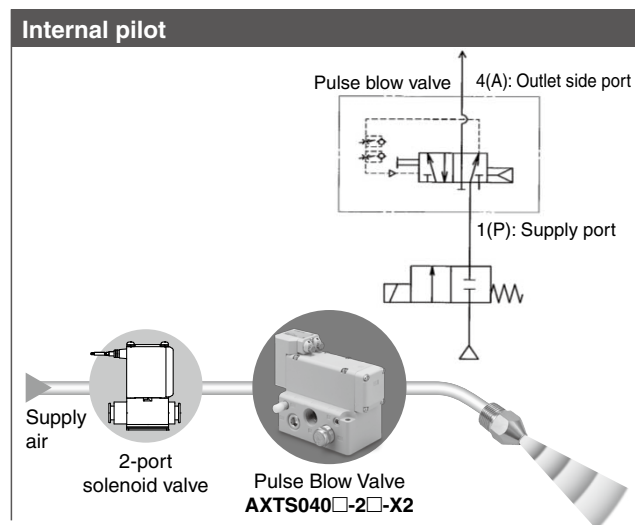
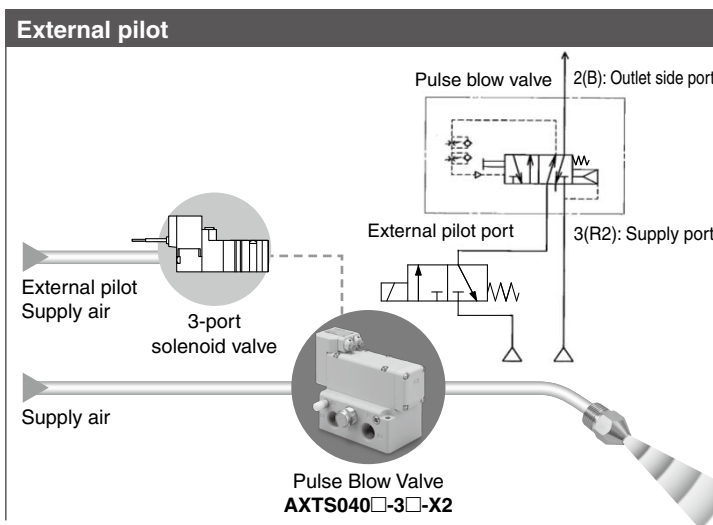

■ Long service life
(Service life: 200 million cycles)

* Based on SMC's test conditions

■ Flow rate characteristics

Type of actuation	C [dm ³ /(s·bar)]	b	Cv
External pilot	14	0.18	3.4
Internal pilot	12	0.14	2.9

■ ON/OFF time adjustable individually

■ Operating pressure range:
0.2 to 1.0 MPa

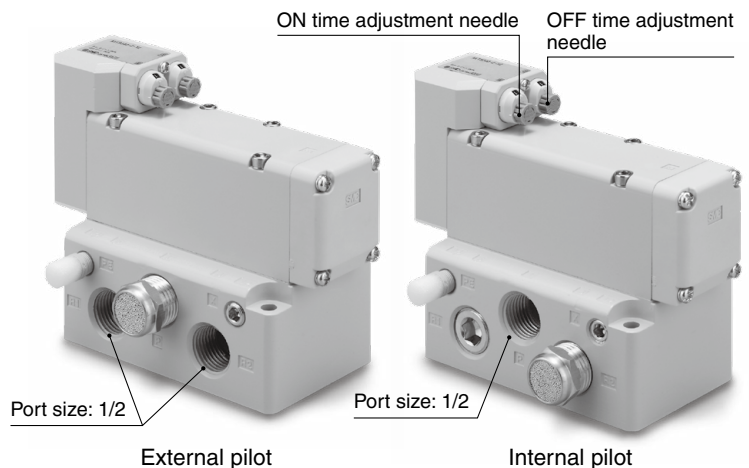

AXTS040□-□□-X2



AXTS040□-□□-X2

How to Order

AXTS 040 □ - 3 □ -X2

Body size	040 1/2	Direct manual override	Nil None
Thread type	Nil Rc	Type of actuation	2 Internal pilot
F G		3 External pilot	
N NPT			
T NPTF			
			B Locking type

Specifications

Model	AXTS040□-2□-X2	AXTS040□-3□-X2	
Type of actuation	Internal pilot	External pilot	
Valve construction	Metal seal		
Fluid	Air		
Operating pressure range	0.2 to 1.0 MPa	0 to 1.0 MPa	
External pilot air pressure	—	0.2 to 1.0 MPa*1	
Frequency adjustment range	1 to 5 Hz	1 to 8 Hz	
Proof pressure	1.5 MPa		
Ambient and fluid temperatures	-10 to 50°C		
Lubrication	Not required		
Flow rate characteristics (IN port → OUT port)	C [dm ³ /(s·bar)]	12	14
	b	0.14	0.18
	Cv	2.9	3.4

*1 Set the external pilot pressure higher than the operating pressure.

Dimensions

Internal pilot

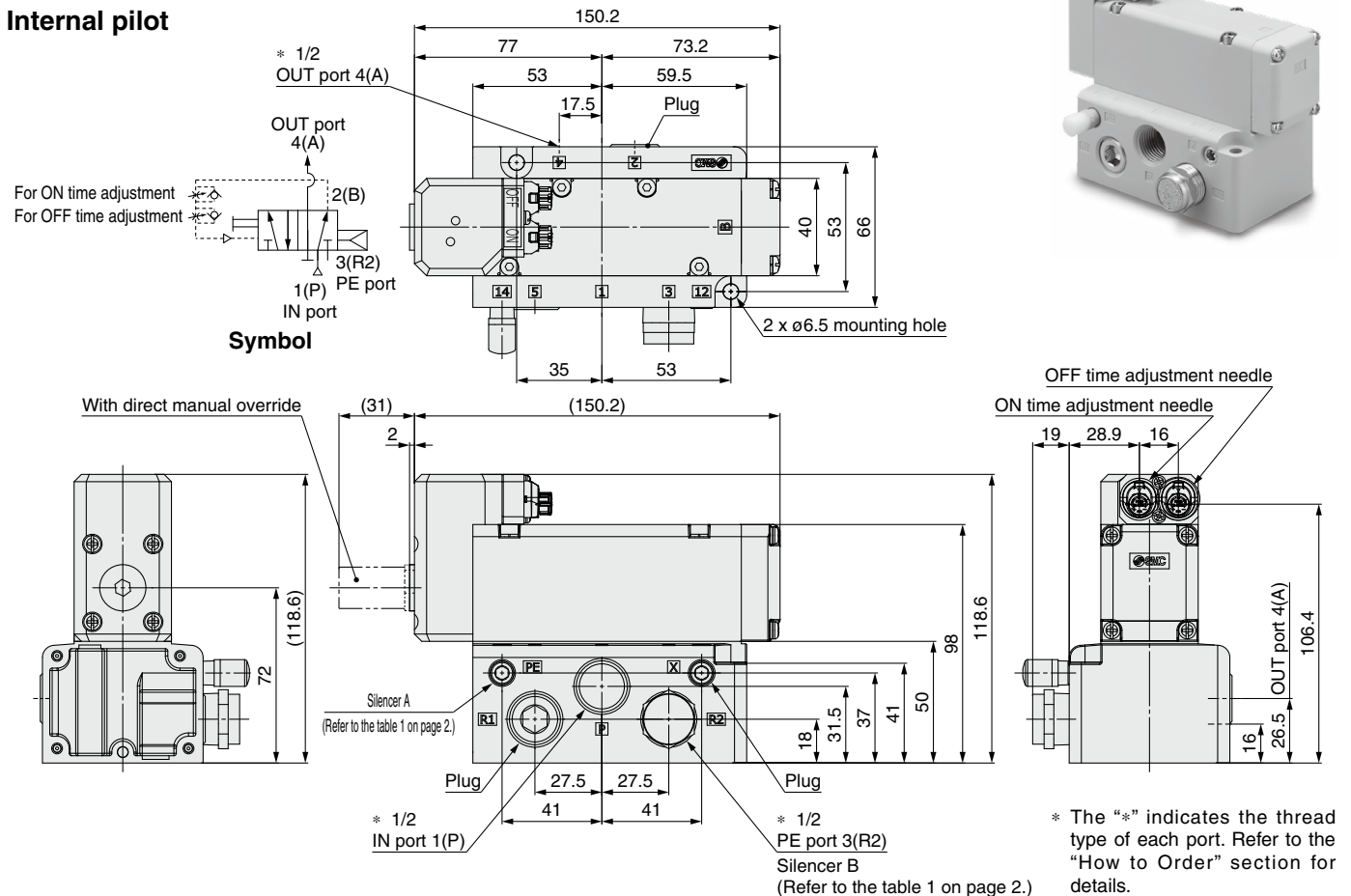

Dimensions

External pilot

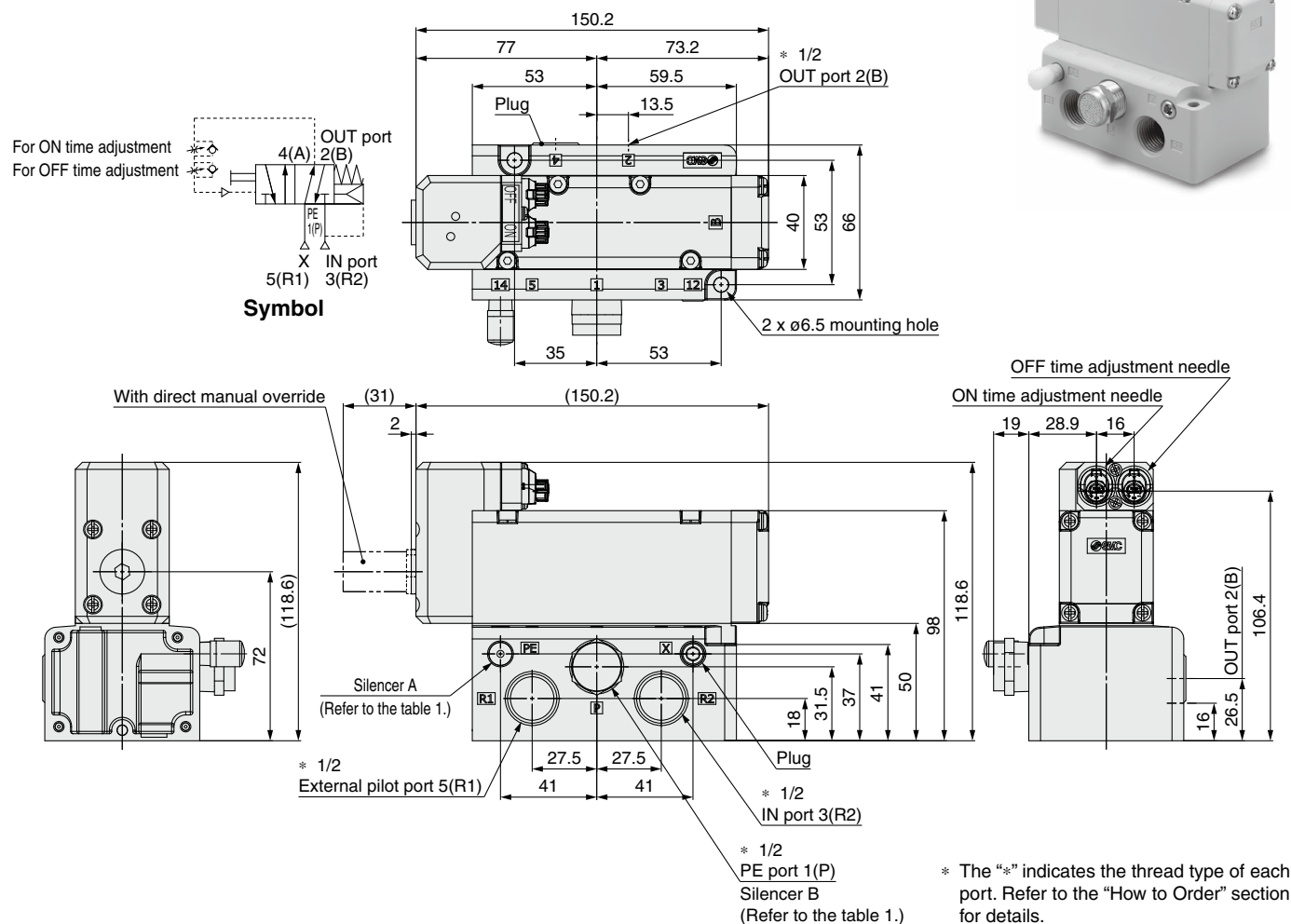

Table 1 Silencer part no.

Product part no.	Thread type	Silencer part no.	
		Silencer A	Silencer B
AXTS040 □□-X2	Rc	AN10-01	EBKX-L7007-120
AXTS040F □□-X2	G		EBKX-L7007F-120
AXTS040N □□-X2	NPT	AN10-N01	EBKX-L7007N-120
AXTS040T □□-X2	NPTF		



AXTS040□-□□-X2 Series

Specific Product Precautions

Be sure to read this before handling the products. For safety instructions and 2-port solenoid valve for fluid control precautions, refer to the “Handling Precautions for SMC Products” and the “Operation Manual” on the SMC website: <https://www.smcworld.com>

Precautions

- This is an air-operated product. If used under conditions where the flow rate is high and there are no pressure drops during operation, there will be no differential pressure inside the valve and it may fail to operate properly as a result.
- The operation frequency fluctuates depending on the operating conditions. Aside from the adjustment needle, the following conditions largely affect the operating frequency. Therefore, if adjustment cannot be made by the needle alone, try making adjustments to the following conditions.

Operation frequency	High ↔ Low
① Inlet side piping diameter ≥ Outlet side piping diameter	The inlet side piping diameter has no effect on the operation frequency.
② Inlet side piping diameter < Outlet side piping diameter	Inlet side piping diameter Large ↔ Small
③ Outlet side piping*1	Bore size Small ↔ Large
	Length Long ↔ Short
④ Supply pressure (External pilot pressure)	Pressure High ↔ Low
⑤ Nozzle	Bore size Small ↔ Large

*1 Blow air may not become pulse air depending on the volume of the downstream. Keep the product close to the nozzle as much as possible.

- The sliding parts of this product are lubricated. Be aware that due to the construction, some lubricant may flow out to the outlet side with the blow air.

Internal Pilot Type

AXTS040□-2□-X2

- When an air gun and a pressure regulator are connected to OUT port, the back pressure of the OUT port will be high. Therefore, the product cannot be used.
- When a vacuum ejector and a suction filter are connected to the OUT port, the back pressure of the OUT port will increase due to the clogging of the filter during operation. As this will result in unstable operation, the product cannot be used. Please use the external pilot type, which is generally not affected by back pressure.

External Pilot Type

AXTS040□-3□-X2

- Use an External pilot pressure higher than IN port pressure.
- For the external pilot type, pulse air is only generated while the pilot air is being supplied. The blow is stopped by the return spring when the pilot air is not being supplied. However, due to the metal seal construction, zero air leakage cannot be guaranteed.
- When the product is used in a condition where the OUT port back pressure varies, for example, vacuum ejector and / or suction filter is connected to the OUT port, please consider that the operation frequency will be changed.

 **Safety Instructions** Be sure to read the "Handling Precautions for SMC Products" (M-E03-3) and "Operation Manual" before use.